



- Socket System Sensor
- Slider Integrated Body
- Easy Mounting
- High Resolution Up to 0,001 mm Resolution
- High Accuracy
- Spiral or Cable Option
- Measuring Lengths Up to 100 m
- Resistant to Humidity
- Sturdy Metal Case
- Protection Class IP67

MLS120 series reader sensors can be used with B series magnetic tape, also PS1 profile system or PS2 profile system. The reader sensor glides contactless over the profile with gap up to 0,1 – 2 mm. MLS 120 sensor has extra protection for the bad environmental conditions by sliders.

Applications:

- Machining Centers
- PVC Cutting Machines
- Wood Cutting Machines
- Lathes, Milling, Drilling, Grinding Machines
- Sheet Metal Working Machines
- Marble Machines
- Welding Machines
- Bending Machines
- Electrical Discharge Machines
- Robotics / Material Handling
- Glass Working Machinery etc...

Technical Specifications

Resolution	1µm, 5µm, 10µm, 25µm, 50µm, 62.5µm, 80µm, 100µm (or on request)
Output Signal Type	Push-Pull or TTL RS422 Line Driver
Output Signals	A, /A, B, /B, Z, /Z
Current	Maximum 40 mA per Channel
Power Supply	10..30 VDC or 5 VDC
Housing Material	Aluminum
Gap Between Tape and Sensor	0,1 mm to 2 mm
Travel Velocity	3 m/s
Repeatability	± 1 Pulse
Operating Temperature Range	-25 to +85°
Protection Class	IP67

Order Specifications

Magnetic Tape

B5
B2

Power Supply and Output

TTL : 5VDC ± %5 Power Supply,
5 VDC TTL RS422 Line Driver Output
PP : 24 VDC ± %20 Power Supply,
24 VDC Push-Pull Output
HTL : 24 VDC ± %20 Power Supply,
5 VDC TTL RS422 Line Driver Output

Cable Length

3M : 3 Meters
5M : 5 Meters
8M : 8 Meters
10M: 10 Meters
* Optional between 5 to 100 Meters

MLS120 - X X - X X - X X X - X - X X - X

Model

Resolution

01 : 1µm | 05 : 5µm
10 : 10µm | 25 : 25µm
62 : 62,5µm | 80 : 80µm
100: 100µm

Signal Output Type

2 : A, B | 3 : A, B, Z
4 : A, /A, B, /B | 6 : A, /A, B, /B, Z, /Z

Optional: One Reference Z Signal

Cable Type

C : Pure Cable
S : Shielded Spiral



Mechanical Dimension

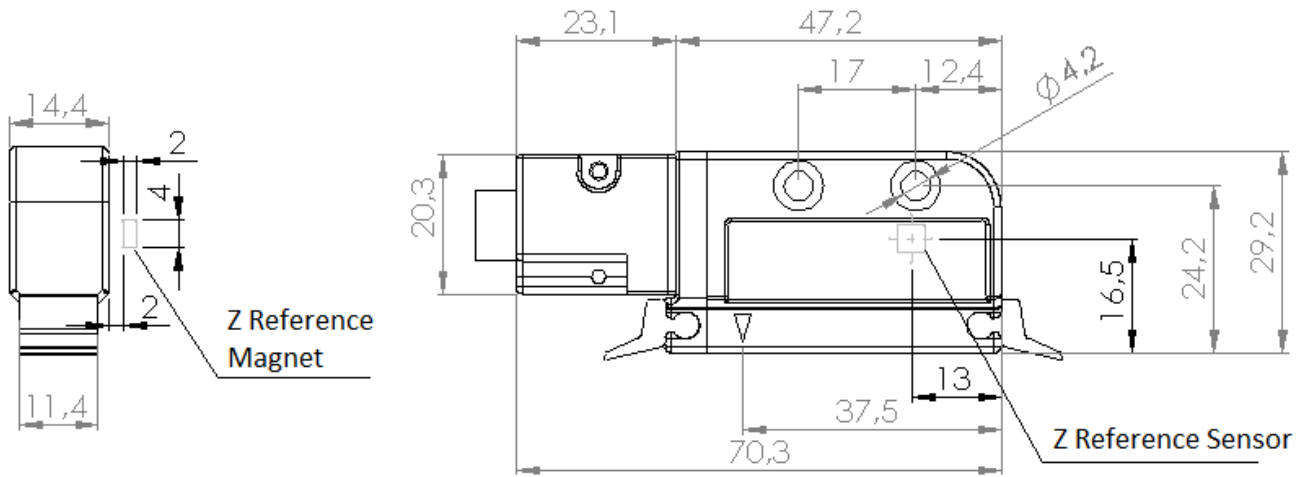

Pin Connections

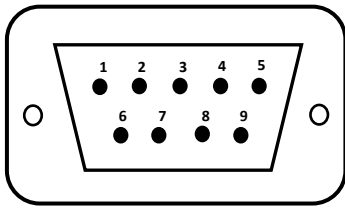

Pin Number	Cable Colour	Signal
1	Yellow	A
2	White	/B
3	Red	POWER SUPPLY
4	Black	0 V
5	Blue	/A
6	Green	B
7	Grey	/Z
8	Pink	Z
9	Shield	GROUND

Magnetic Tape and Profile Systems That Can Be Used With MLS 110 Reader Sensor:

- PS1 Profile System
- PS2 Profile System
- B Series Magnetic Tape

